

Teacher FON/ MCL/ PER	Class:	Name [Print clearly]
---------------------------------	---------------	-----------------------------



NOVEMBER EXAMINATIONS 2014

SUBJECT: Year 7 Mathematics

Time allowed: 2 Hours

Total Marks: 180

READ THESE INSTRUCTIONS FIRST

Answer all questions

The number of marks is given in brackets [] at the end of each question or part question.

This is a question and answer booklet. Write your answers in the spaces provided.

You may use a calculator.

SHOW YOUR WORKING for any question worth more than 1 mark

Do not use staples, paper clips, highlighters, glue or correction fluid.

Write in dark blue or black pen. You may use a pencil for diagrams, graphs or rough working.

Topic	Marks
Semester One	65
Geometry	25
Statistics	20
Algebra	10
Time	10
Transformation Geometry	12
Probability	12
Problem Solving	26
Total Marks:	180

Semester One

1 Give the first 3

a) square numbers _____ [1]

b) prime numbers _____ [1]

c) multiples of 4 _____ [1]

2 List the factors of 18 in factor pairs. _____ [2]

3 Round 563 to:

a) the nearest 5 _____ [1]

b) How would you write 563 using one figure approximation?
_____ [1]

4 Using the numbers 19 and 8, show full working to find:

a) the difference of the two numbers

_____ [2]

b) the product of the two numbers

_____ [2]

c) the sum of the two numbers.

_____ [2]

5 Calculate the following (showing full working):

a) $9984 \div 12$

b) $6 + 9 \div 3 - 4 =$

_____ [2]

_____ [1]

6 Insert a pair of brackets to make the following sentence true:

$$5 + 3 \times 7 - 2 = 20$$

[1]

7 Write 48 as a product of its prime factors.

_____ [2]

8 Alex buys a table that is 2.5 m long and 1.2 m wide.

a) Calculate the area of the table.

_____ [2]

b) Calculate the perimeter of the table.

_____ [2]

c) The table top is made of wood and is 5 cm thick.
Calculate the volume of the table top.

_____ [2]

9

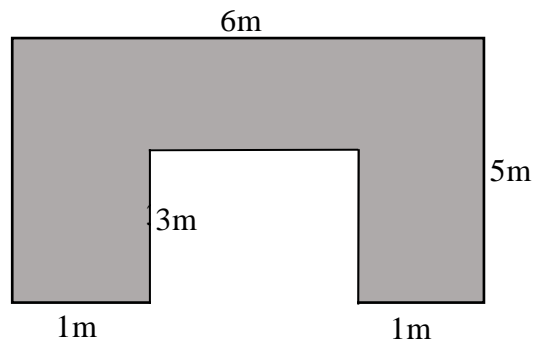

a) Find the perimeter of the shape.

_____ [2]

b) What is the area of the shape?

_____ [2]

10

a) Below is a glass vase. What is the volume of the vase?

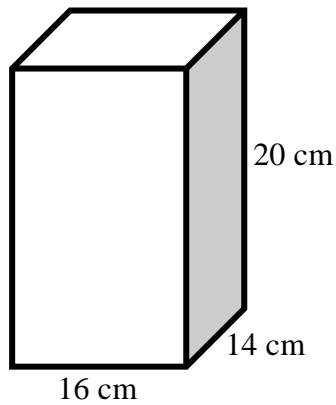

_____ [2]

b) What is half of the capacity of the vase?

_____ [1]

c) If you wanted to cover the outside (including the bottom) of the vase with 2 cm square tiles, how many tiles would you need?

_____ [2]

11 The world's longest tunnel at the moment is in France and is approximately 9978 metres long. How long is this in kilometres?

_____ [1]

12 On the grid below draw the following:

a) the x and y axes from 0 to 16 [2]

b) Plot the points $A(4,12)$, $B(8,12)$, $C(15,4)$ and $D(3,4)$ and clearly label each point.
Draw a line from A to B , B to C , C to D and D to A .

[2]

c) What is the special name given to the quadrilateral $ABCD$?

[1]

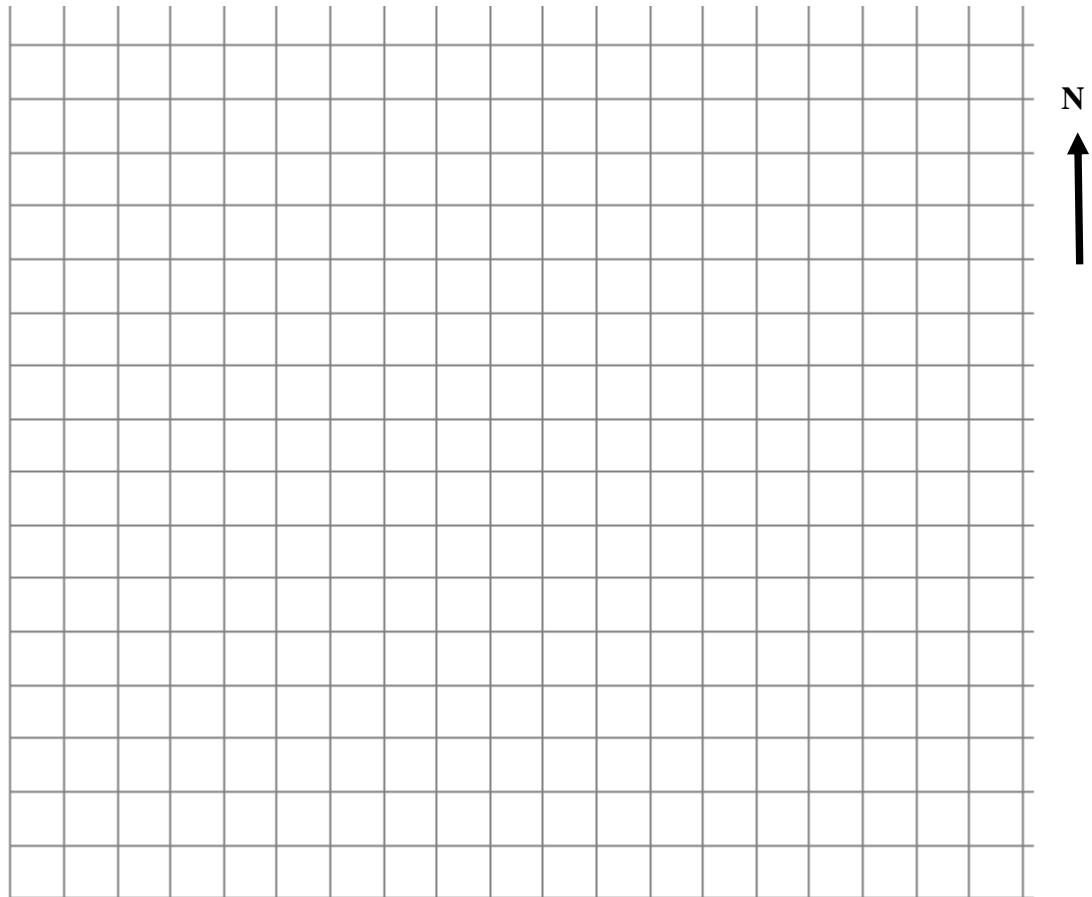

d) What is the compass direction **from B to C**? _____ [1]

13 Using the number **52.946** answer the following questions.

a) What is the value of the 9 digit? _____ [1]

b) Write the number as a mixed number.

c) Write the number using 1 figure approximation _____ [1]

_____ [1]

14 By showing full working

a) calculate

$$12.38 + 12.9 + 12.05$$

_____ [2]

b) find the difference between the largest and smallest of the 3 numbers in part (a).

_____ [2]

15 Calculate showing full working.

a) $2.3 \times 1.2 =$

_____ [2]

b) $8.632 \div 5 =$

_____ [2]

16 Complete the fractions shown.

a) $\frac{3}{12} = \frac{\quad}{4} = \frac{6}{\quad}$

[2]

b) Simplify $\frac{16}{28}$ as far as possible.

_____ [2]

c) Rewrite $\frac{31}{5}$ as a mixed number.

_____ [1]

d) Turn $3\frac{5}{7}$ into an improper fraction.

_____ [1]

e) $\frac{1}{6} + \frac{4}{6} =$

_____ [1]

f) $\frac{8}{15} - \frac{4}{15} =$

_____ [1]

17 John catches 36 frogs in his traps but $\frac{4}{9}$ of them escape before he can put them in his bag. How many does he manage to get into his bag?

_____ [2]

18 Convert $\frac{5}{8}$

a) Into a decimal.

_____ [1]

b) into a percentage

_____ [1]

19 Find 17% of 300.

_____ [1]

Geometry

20 Write the correct name of each Geometric figure drawn below.

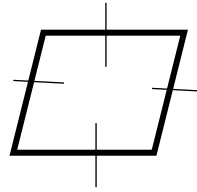
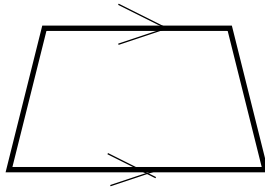
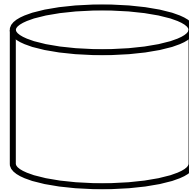
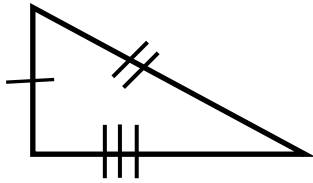

[4]

21

a) Draw the net of the figure below using a pencil and ruler. There is no need to label the vertices.

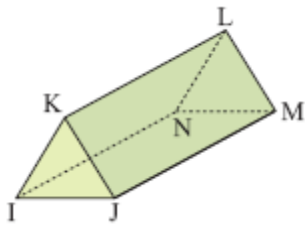

[2]

b) How many faces does the figure above have?

_____ [1]

c) How many vertices does the figure have?

_____ [1]

22.

- a) Draw an isometric projection of the shape below with the edge A as the front edge.

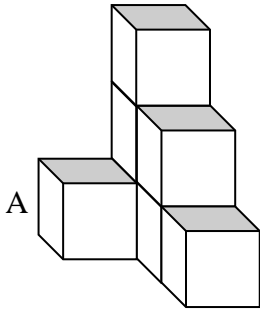

[2]

- b) Draw plan, elevation and end elevation views of the above shape.

[3]

23.

- a) Measure and write down the size of angle AOD _____ [1]

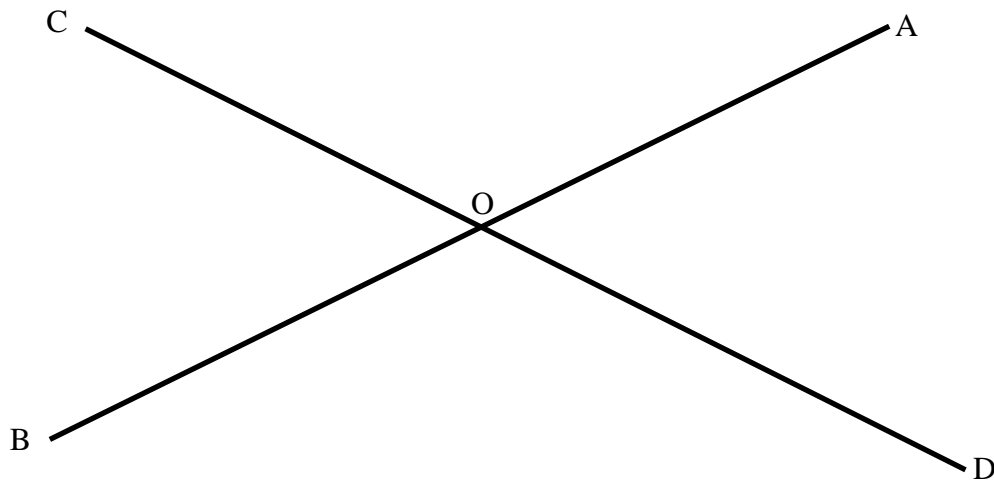

- b) Classify what type of angle BOD is. _____ [1]

- c) Using 3 point notation name 2 angles that add up to 180° .

_____ [1]

24. Complete the sentence: A prism has a _____ [1]

25. Accurately draw a 40° angle **and** label it ABC in the box provided.

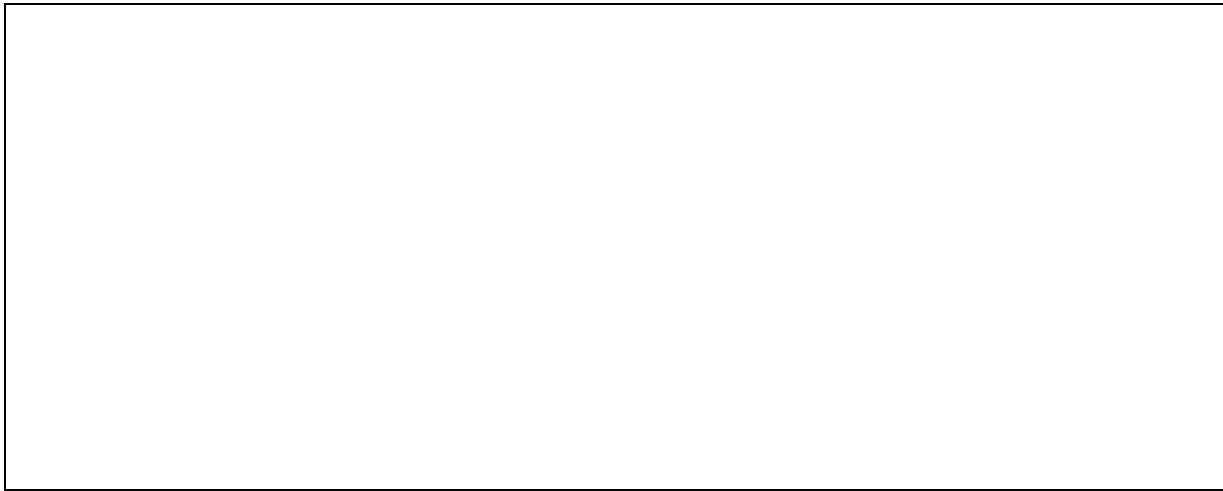

[2]

26. Accurately draw a parallelogram in the box below.

Include all of the required symbols that a parallelogram must have.

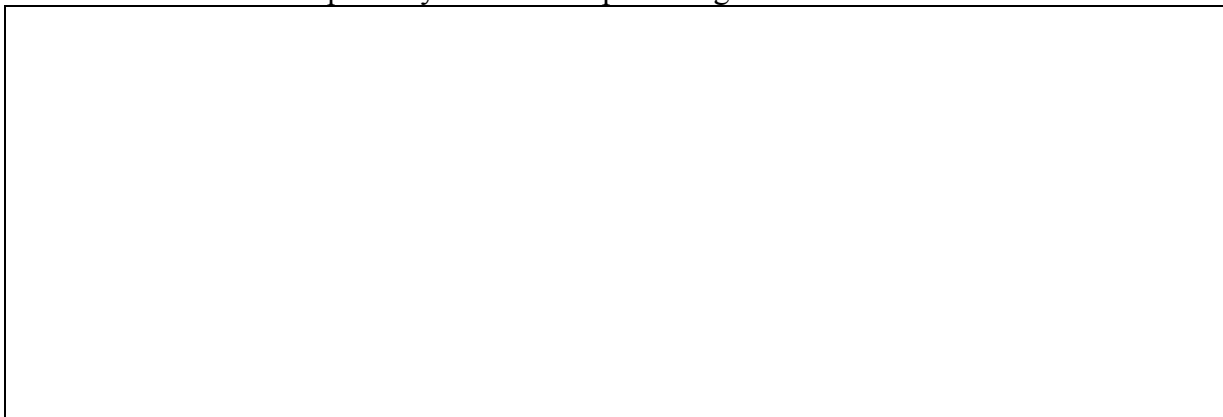

[2]

27. Draw a 3 cm radius circle. Draw **and label** a radius, diameter and arc.

[4]

Statistics

28. a) Complete the frequency table below for weight of a flock of sheep.

Weight (kg)	Tally	Frequency
8	IIII	
9	II	
10		2
11		1
12	III	
13		2
14		3
15	II	2
16		1

[2]

b) How many sheep are there in total?

_____ [1]

c) Draw a dot plot of the data given in the table above.

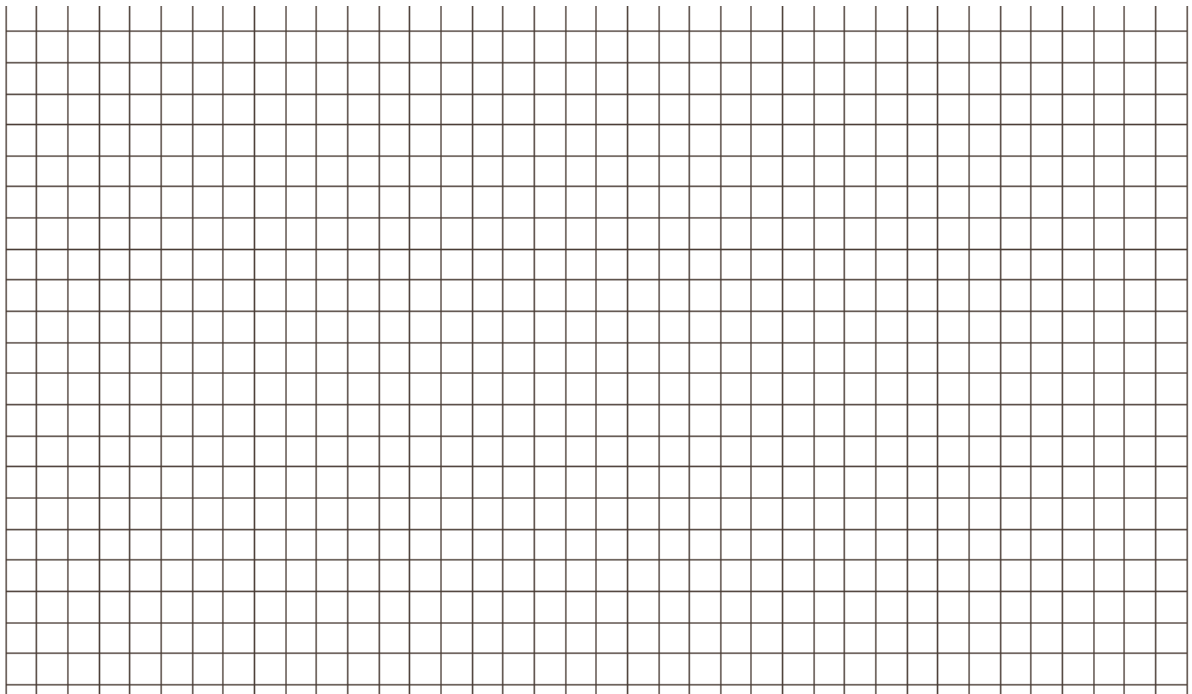

[3]

d) Draw a stem and leaf plot for the same set of data.

e) Draw a Strip graph of the same data.

[3]

[3]

29 On a fishing trip 8 fish were caught. The weight of each fish is listed below.

2, 3, 3, 2, 4, 3, 2, 5

a) Use this data to complete the table below

Weight of fish (kg)	Number of fish
2	
3	
4	
5	

[1]

b) Calculate the mean weight of the fish caught. (full working must be shown)

_____ [2]

- c) Draw a Pie graph of the fish data using the circle drawn for you.
Full working must be shown.

[5]

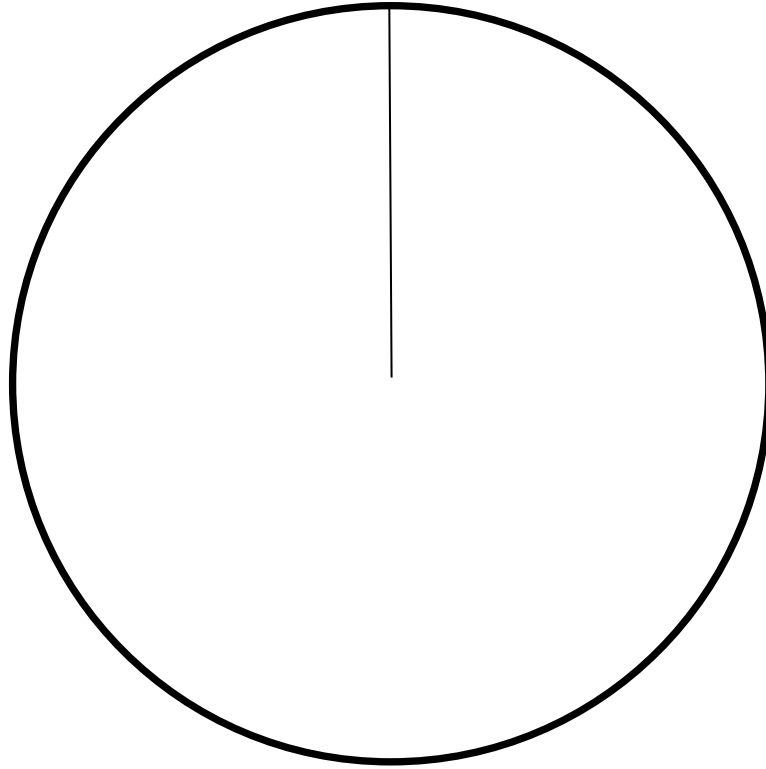

Algebra

30 Using the sequence **3 7 11 15**

a) Give the next term in the sequence. _____ [1]

b) Write in sentence form the rule to find the next member of the sequence.

_____ [2]

31 A paper company sells boxes of paper for \$6 per box and they only charge \$5 to deliver an order of paper no matter how many boxes are ordered.

a) If C is the total cost of the order including the delivery charge, P is the number of boxes of paper, write the formula in symbolic form.
_____ [2]

b) Use the formula to find out how much it would cost to buy 7 boxes of paper and have it delivered.
_____ [1]

c) If an order cost \$77 for paper and delivery calculate how many boxes of paper were delivered.
_____ [2]

32 a) If Alex is 12 years old how old will he be in n years time?
_____ [1]

b) If a ruler is m cm long, how long would 4 of the rulers be?
_____ [1]

Time

33 Complete the tables below.

a)

2 hours 16 minutes	minutes
35 minutes	seconds
2 decades	years
4 days 11 hours	hours
570 minutes	hours

[5]

b) Convert the times

<u>12 hour time</u>	<u>24 hour time</u>
9.30 pm	
	0515
	1924
12.05 am	

[4]

34 If Albert leaves home at 7.35 am and arrives in Hamilton at 10.15 am, calculate how long it took for the journey.

_____ [1]

Transformation Geometry

35 a) Reflect the **shape A** in the mirror line **M1** and label the image B [1]

b) Reflect **B** in the mirror line **M2** and label the image C [1]

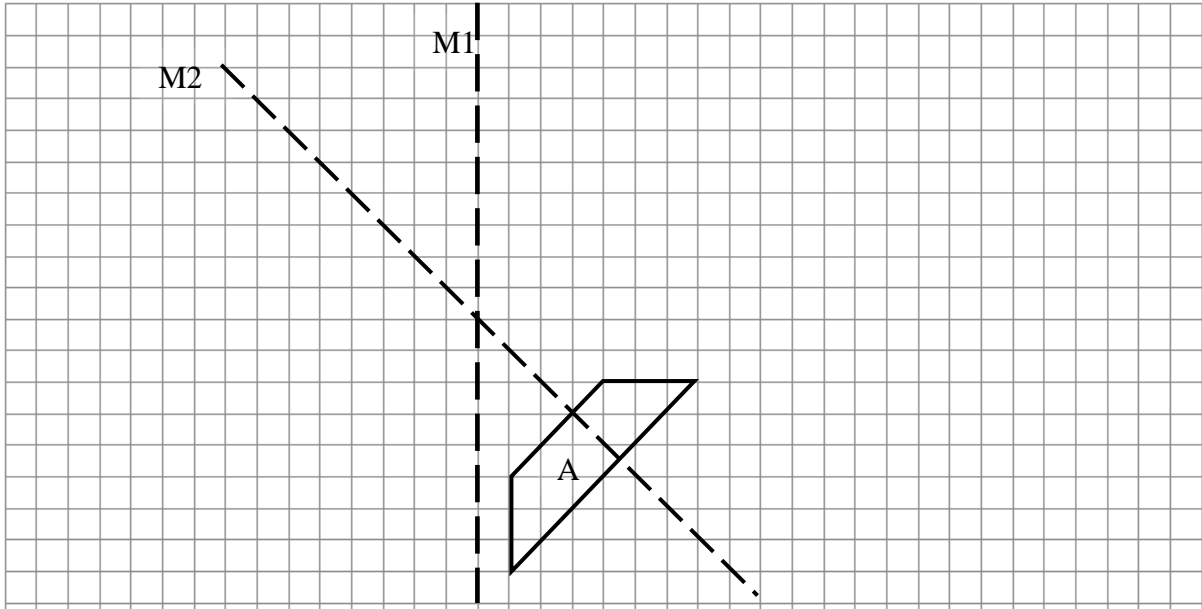

36 Circle the faces that could be a reflection of Happy face. [2]

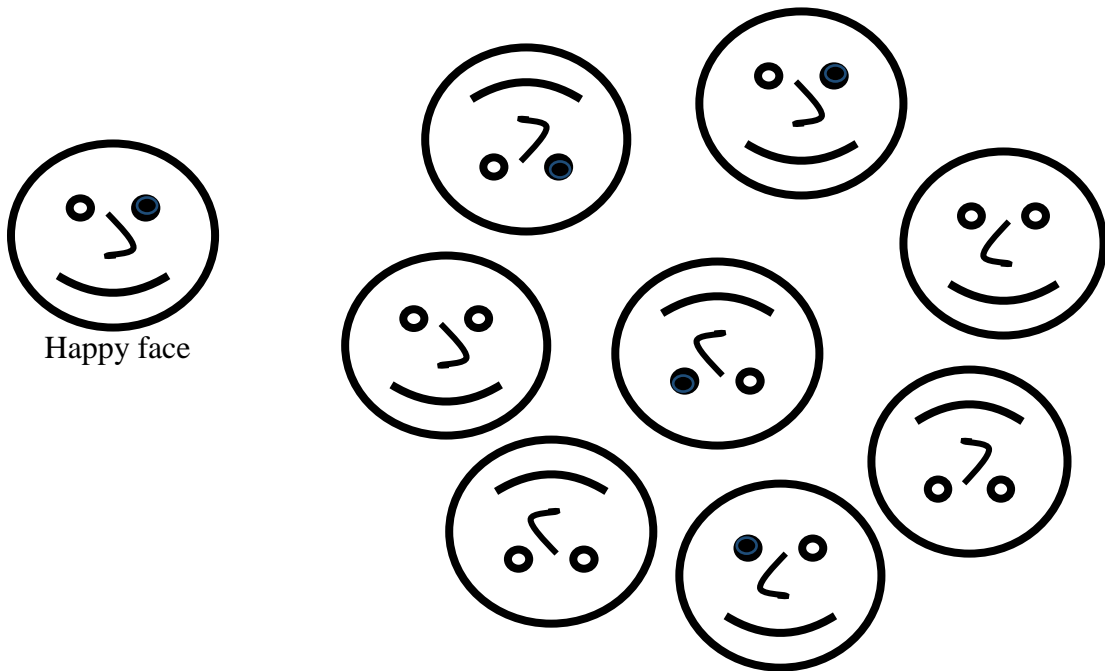

- 37 a) Rotate shape A 90° anticlockwise and label the new shape B [1]
 b) Rotate shape A 180° and label it C [1]
 c) Enlarge A by a scale factor of $\frac{1}{2}$ and label it D [1]

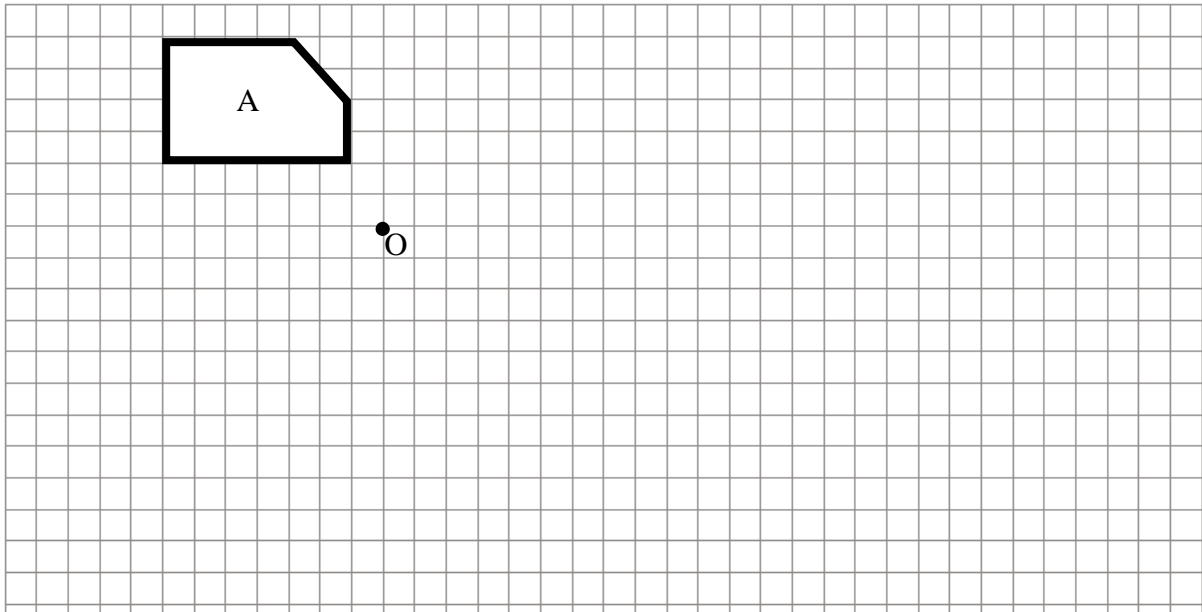

38

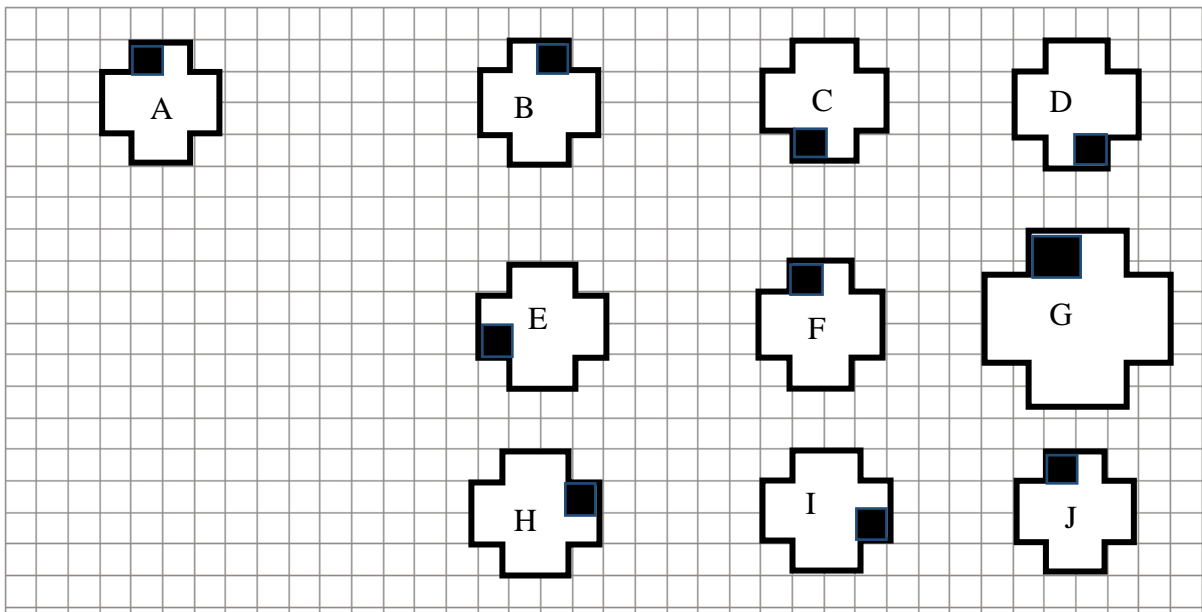

Shapes B to J are all the result of a transformation of shape A. (shapes can be used more than once)

- a) Which shapes are reflections of A? _____ [2]
 b) Which shapes are rotations of A? _____ [2]
- 39 How many lines of symmetry does a regular pentagon have? _____ [1]

Probability

40 a) What is the probability of getting a 5 when a die is rolled?

_____ [1]

b) What is the probability of rolling an even number?

_____ [1]

c) If 2 dice are rolled what is the probability that the two numbers total 7?

_____ [2]

41 In a survey of 25 students 12 said their favourite vegetable was carrots, 6 said lettuce and the rest said they didn't eat vegetables at all.

a) What is the probability that a randomly chosen student from this group eats vegetables?

_____ [2]

b) Estimate the total number of students in a school of 400 who have carrots as their favourite

_____ [2]

c) Estimate the number who don't eat any vegetables.

_____ [1]

- 42 There are 2 spinners shown below. The first spinner has numbers 1 to 4 and the second spinner has A and B.
- a) Draw a tree diagram showing all of the possible outcomes.

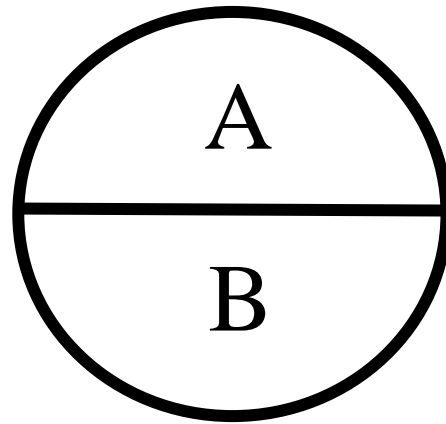
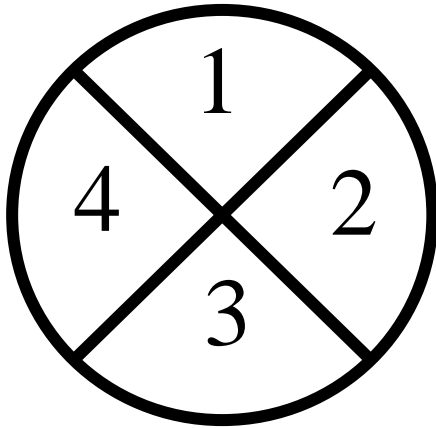

[3]

Problem Solving

- 43 12 bottles of water fill $\frac{3}{4}$ of a 20 litre bucket.
How much water is in each bottle?

_____ [2]

- 44 A school has 600 students. 19% of the students ride a bike to school, 27% are driven by parents, and 18% catch the bus. The remainder of the students walk to school.

a) How many students are driven to school by parents?

_____ [1]

b) How many walk to school?

_____ [2]

- 45 Mr Bot makes robot spiders and insects. Spiders have 8 legs and insects have 6 legs. He has 25 heads and 180 legs to make his robots and he knows he will use up all the pieces if he make the right number of each.
How many spiders and insects does he make?

Spiders_____

Insects_____

[3]

- 46 Cici and Amanda have lots of stickers. Cici has twice as many as Amanda. Cici gave Amanda 5 stickers so that that both had the same number of stickers.
How many stickers did each girl start with?

Amanda_____

Cici_____ [3]

- 47 Frank's sister is 4 times as old as Frank. The product of their ages is 144.
How old is Frank and his sister?

Frank_____

Sister_____ [3]

- 48 Mr Strange died and in his will he left half of his money to his wife, \$13000 went to his daughter, half of what was left went to his son, half of what was left was given to his cat and the remaining \$3000 to his mouse. How much money did his wife get?

Wife_____ [2]

- 49 The average weight of 4 men is 70 kg. Another man is added to the group and the average is now 72 kg. How much does the extra man weigh?

Extra man_____ [3]

- 50 Jack and Tim decide to buy some food. They can buy donuts and hamburgers. They have enough money to buy 30 donuts **or** 20 hamburgers. They decided to buy 18 donuts.
How many hamburgers can they then buy with money have left over?

hamburgers_____ [3]

51 a) Three consecutive numbers **add** up to 24, what is the largest number?

_____ [2]

b) A different set of three consecutive numbers multiply to equal 4080.
What is largest of the three numbers?

_____ [2]

The end